

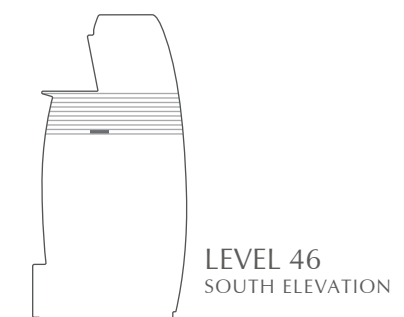

RESIDENCES

at
300 BISCAYNE BOULEVARD WAY
MIAMI

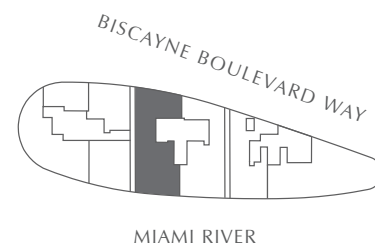
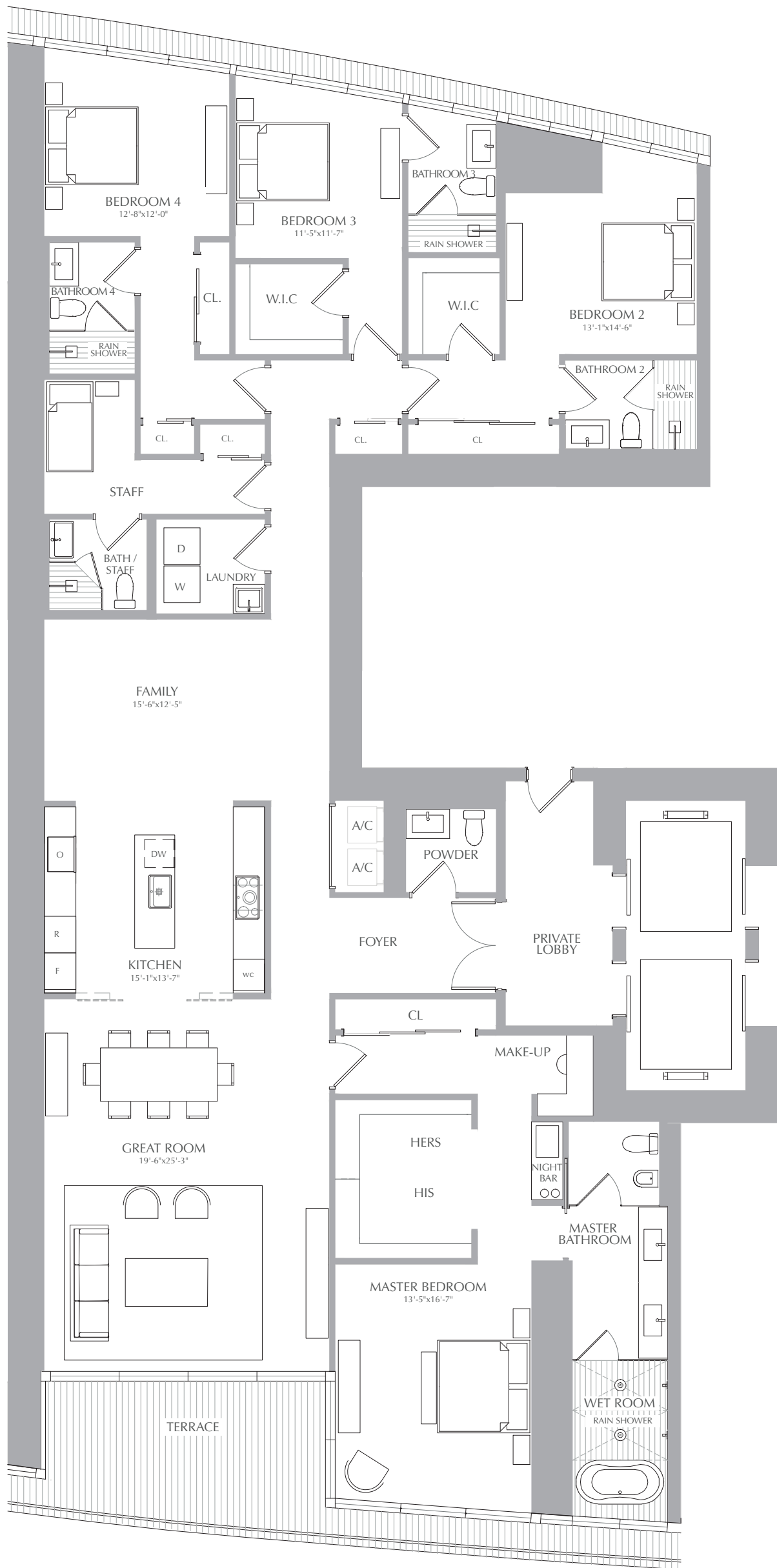
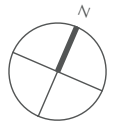

LEVEL 46
SOUTH ELEVATION



STATED SQUARE FOOTAGES AND DIMENSIONS ARE MEASURED TO THE EXTERIOR BOUNDARIES OF THE EXTERIOR WALLS AND THE CENTERLINE OF INTERIOR DEMISING WALLS AND IN FACT VARY FROM THE SQUARE FOOTAGE AND DIMENSIONS THAT WOULD BE DETERMINED BY USING THE DESCRIPTION AND DEFINITION OF THE "UNIT" SET FORTH IN THE DECLARATION (WHICH GENERALLY ONLY INCLUDES THE INTERIOR AIRSPACE BETWEEN THE PERIMETER WALLS AND EXCLUDES ALL INTERIOR STRUCTURAL COMPONENTS AND OTHER COMMON ELEMENTS). THIS METHOD IS GENERALLY USED IN SALES MATERIALS AND IS PROVIDED TO ALLOW A PROSPECTIVE BUYER TO COMPARE THE UNITS WITH UNITS IN OTHER CONDOMINIUM PROJECTS THAT UTILIZE THE SAME METHOD. FOR YOUR REFERENCE, THE AREA OF THE UNIT, DETERMINED IN ACCORDANCE WITH THESE DEFINED UNIT BOUNDARIES, IS 4,369 SQ. FT. MEASUREMENTS OF ROOMS SET FORTH ON THIS FLOOR PLAN ARE GENERALLY TAKEN AT THE FARTHEST POINTS OF EACH GIVEN ROOM (AS IF THE ROOM WERE A PERFECT RECTANGLE), WITHOUT REGARD FOR ANY CUTOUTS OR VARIATIONS. ACCORDINGLY, THE AREA OF THE ACTUAL ROOM WILL TYPICALLY BE SMALLER THAN THE PRODUCT OBTAINED BY MULTIPLYING THE STATED LENGTH AND WIDTH. ALL DIMENSIONS ARE ESTIMATES WHICH WILL VARY WITH ACTUAL CONSTRUCTION, AND ALL FLOOR PLANS, SPECIFICATIONS AND OTHER DEVELOPMENT PLANS ARE SUBJECT TO CHANGE AND WILL NOT NECESSARILY ACCURATELY REFLECT THE FINAL PLANS AND SPECIFICATIONS FOR THE DEVELOPMENT. ALL DEPICTIONS OF APPLIANCES, COUNTERS, SOFFITS, FLOOR COVERINGS AND OTHER MATTERS OF DETAIL, INCLUDING, WITHOUT LIMITATION, ITEMS OF FINISH AND DECORATION, ARE CONCEPTUAL ONLY AND ARE NOT NECESSARILY INCLUDED IN EACH UNIT.



RESIDENCES

at
300 BISCAYNE BOULEVARD WAY
MIAMI

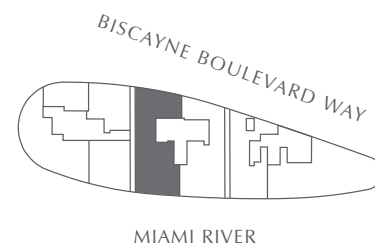
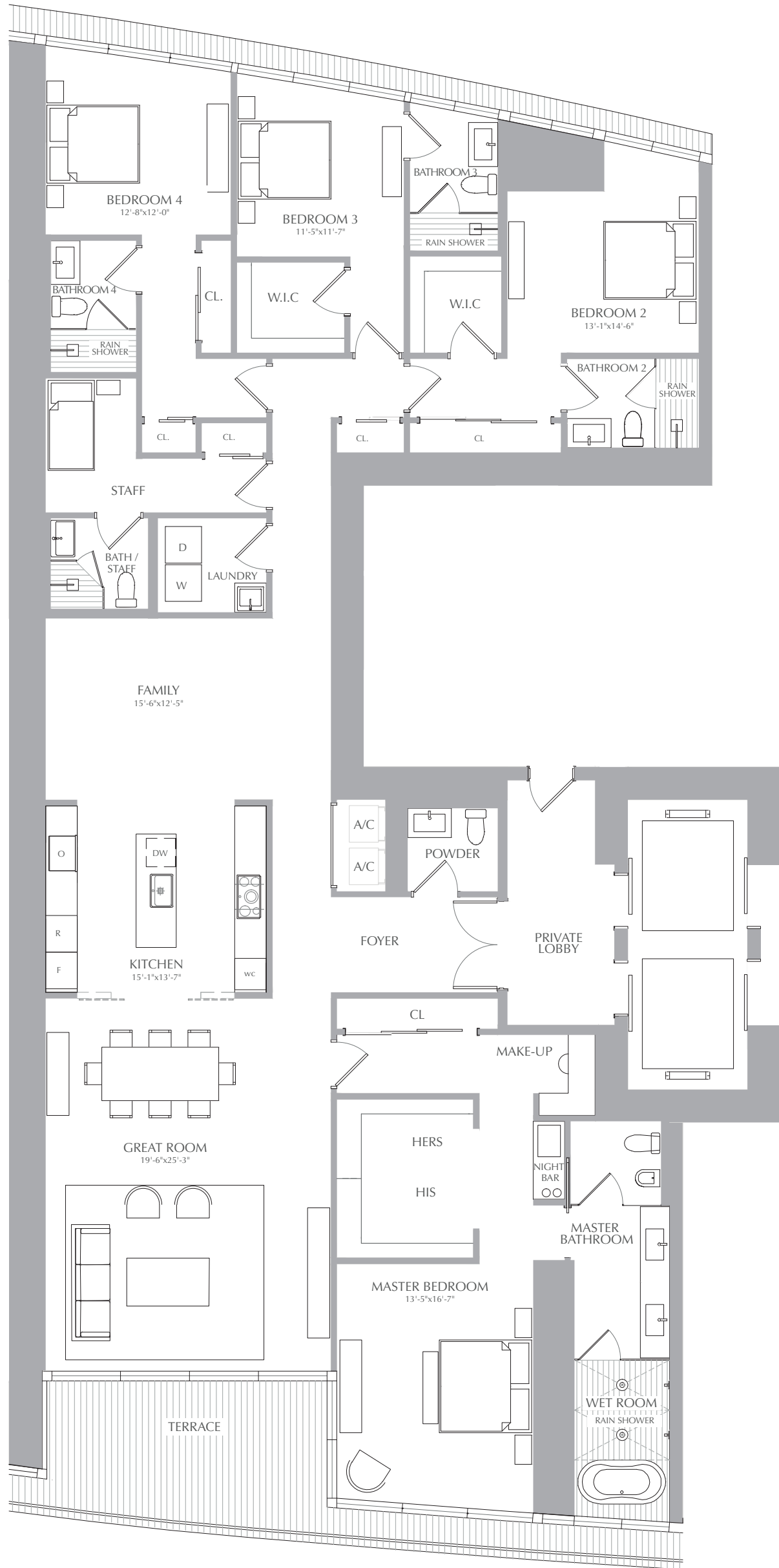
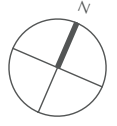

Equal Housing Opportunity

STATED SQUARE FOOTAGES AND DIMENSIONS ARE MEASURED TO THE EXTERIOR BOUNDARIES OF THE EXTERIOR WALLS AND THE CENTERLINE OF INTERIOR DEMISING WALLS AND IN FACT VARY FROM THE SQUARE FOOTAGE AND DIMENSIONS THAT WOULD BE DETERMINED BY USING THE DESCRIPTION AND DEFINITION OF THE "UNIT" SET FORTH IN THE DECLARATION (WHICH GENERALLY ONLY INCLUDES THE INTERIOR AIRSPACE BETWEEN THE PERIMETER WALLS AND EXCLUDES ALL INTERIOR STRUCTURAL COMPONENTS AND OTHER COMMON ELEMENTS). THIS METHOD IS GENERALLY USED IN SALES MATERIALS AND IS PROVIDED TO ALLOW A PROSPECTIVE BUYER TO COMPARE THE UNITS WITH UNITS IN OTHER CONDOMINIUM PROJECTS THAT UTILIZE THE SAME METHOD. FOR YOUR REFERENCE, THE AREA OF THE UNIT, DETERMINED IN ACCORDANCE WITH THESE DEFINED UNIT BOUNDARIES, IS 4,369 SQ. FT. MEASUREMENTS OF ROOMS SET FORTH ON THIS FLOOR PLAN ARE GENERALLY TAKEN AT THE FARTHEST POINTS OF EACH GIVEN ROOM (AS IF THE ROOM WERE A PERFECT RECTANGLE), WITHOUT REGARD FOR ANY CUTOUTS OR VARIATIONS. ACCORDINGLY, THE AREA OF THE ACTUAL ROOM WILL TYPICALLY BE SMALLER THAN THE PRODUCT OBTAINED BY MULTIPLYING THE STATED LENGTH AND WIDTH. ALL DIMENSIONS ARE ESTIMATES WHICH WILL VARY WITH ACTUAL CONSTRUCTION, AND ALL FLOOR PLANS, SPECIFICATIONS AND OTHER DEVELOPMENT PLANS ARE SUBJECT TO CHANGE AND WILL NOT NECESSARILY ACCURATELY REFLECT THE FINAL PLANS AND SPECIFICATIONS FOR THE DEVELOPMENT. ALL DEPICTIONS OF APPLIANCES, COUNTERS, SOFFITS, FLOOR COVERINGS AND OTHER MATTERS OF DETAIL, INCLUDING, WITHOUT LIMITATION, ITEMS OF FINISH AND DECORATION, ARE CONCEPTUAL ONLY AND ARE NOT NECESSARILY INCLUDED IN EACH UNIT.

4 BEDROOMS
5.5 BATHROOMS
STAFF + FAMILY

INTERIOR: 3,536 SQ. FT. 329 SQ. M.
EXTERIOR: 194 SQ. FT. 18 SQ. M.
TOTAL: 3,730 SQ. FT. 347 SQ. M.



ASTON MARTIN

RESIDENCES

at
300 BISCAYNE BOULEVARD WAY
MIAMI

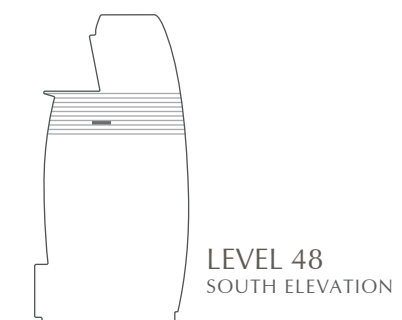
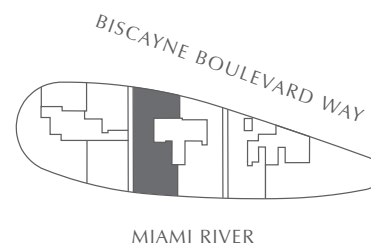
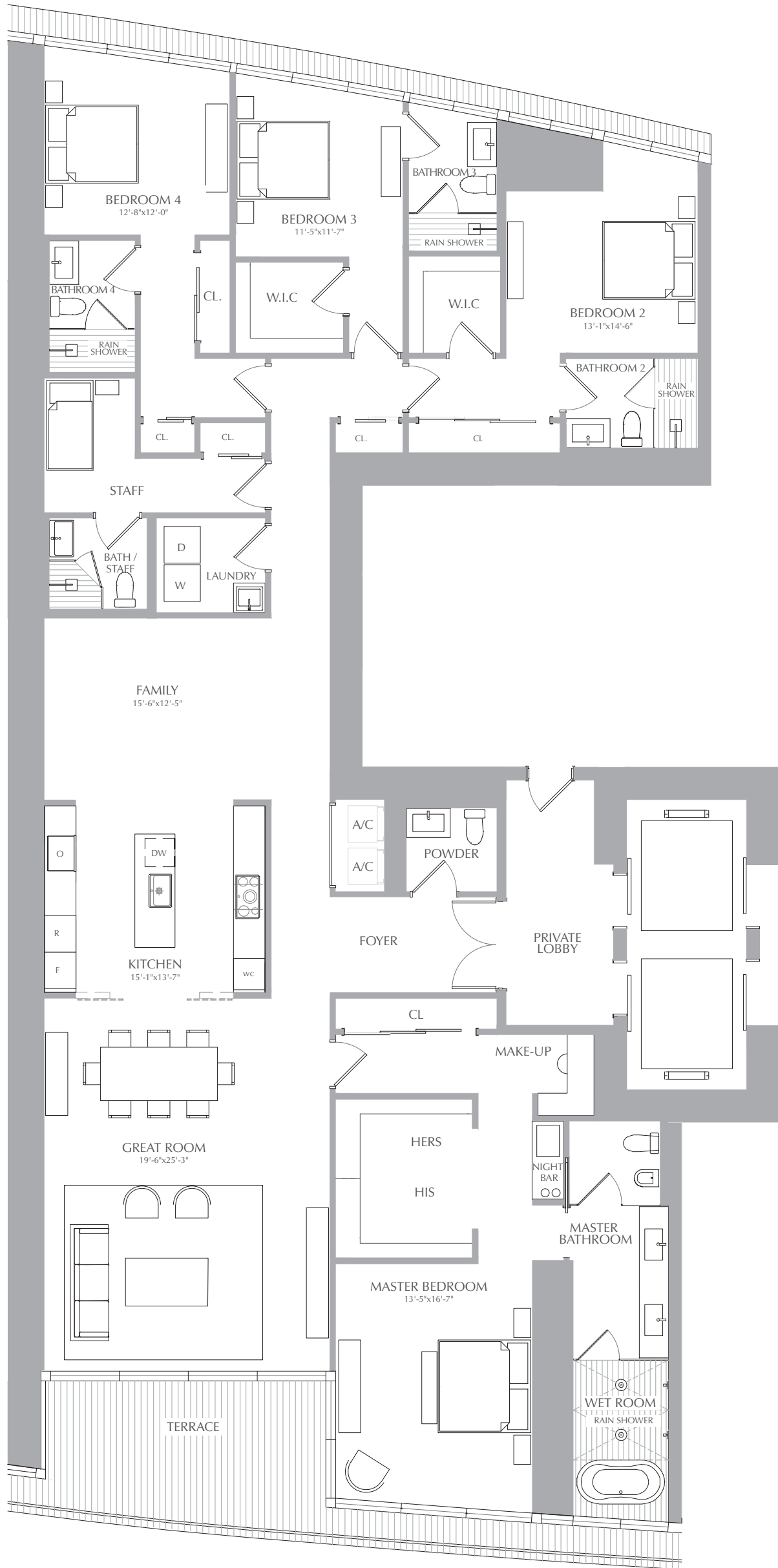
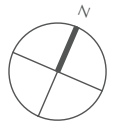

STATED SQUARE FOOTAGES AND DIMENSIONS ARE MEASURED TO THE EXTERIOR BOUNDARIES OF THE EXTERIOR WALLS AND THE CENTERLINE OF INTERIOR DEMISING WALLS AND IN FACT VARY FROM THE SQUARE FOOTAGE AND DIMENSIONS THAT WOULD BE DETERMINED BY USING THE DESCRIPTION AND DEFINITION OF THE "UNIT" SET FORTH IN THE DECLARATION (WHICH GENERALLY ONLY INCLUDES THE INTERIOR AIRSPACE BETWEEN THE PERIMETER WALLS AND EXCLUDES ALL INTERIOR STRUCTURAL COMPONENTS AND OTHER COMMON ELEMENTS). THIS METHOD IS GENERALLY USED IN SALES MATERIALS AND IS PROVIDED TO ALLOW A PROSPECTIVE BUYER TO COMPARE THE UNITS WITH UNITS IN OTHER CONDOMINIUM PROJECTS THAT UTILIZE THE SAME METHOD. FOR YOUR REFERENCE, THE AREA OF THE UNIT, DETERMINED IN ACCORDANCE WITH THESE DEFINED UNIT BOUNDARIES, IS 4,369 SQ. FT. MEASUREMENTS OF ROOMS SET FORTH ON THIS FLOOR PLAN ARE GENERALLY TAKEN AT THE FARTHEST POINTS OF EACH GIVEN ROOM (AS IF THE ROOM WERE A PERFECT RECTANGLE), WITHOUT REGARD FOR ANY CUTOUTS OR VARIATIONS. ACCORDINGLY, THE AREA OF THE ACTUAL ROOM WILL TYPICALLY BE SMALLER THAN THE PRODUCT OBTAINED BY MULTIPLYING THE STATED LENGTH AND WIDTH. ALL DIMENSIONS ARE ESTIMATES WHICH WILL VARY WITH ACTUAL CONSTRUCTION, AND ALL FLOOR PLANS, SPECIFICATIONS AND OTHER DEVELOPMENT PLANS ARE SUBJECT TO CHANGE AND WILL NOT NECESSARILY ACCURATELY REFLECT THE FINAL PLANS AND SPECIFICATIONS FOR THE DEVELOPMENT. ALL DEPICTIONS OF APPLIANCES, COUNTERS, SOFFITS, FLOOR COVERINGS AND OTHER MATTERS OF DETAIL, INCLUDING, WITHOUT LIMITATION, ITEMS OF FINISH AND DECORATION, ARE CONCEPTUAL ONLY AND ARE NOT NECESSARILY INCLUDED IN EACH UNIT.



RESIDENCES

at
300 BISCAYNE BOULEVARD WAY
MIAMI

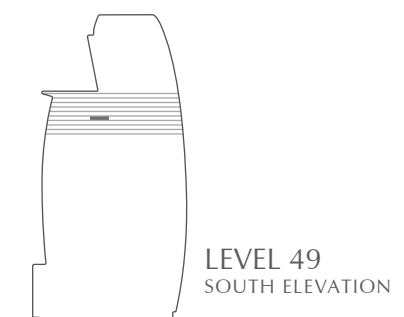
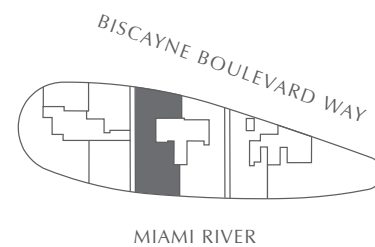
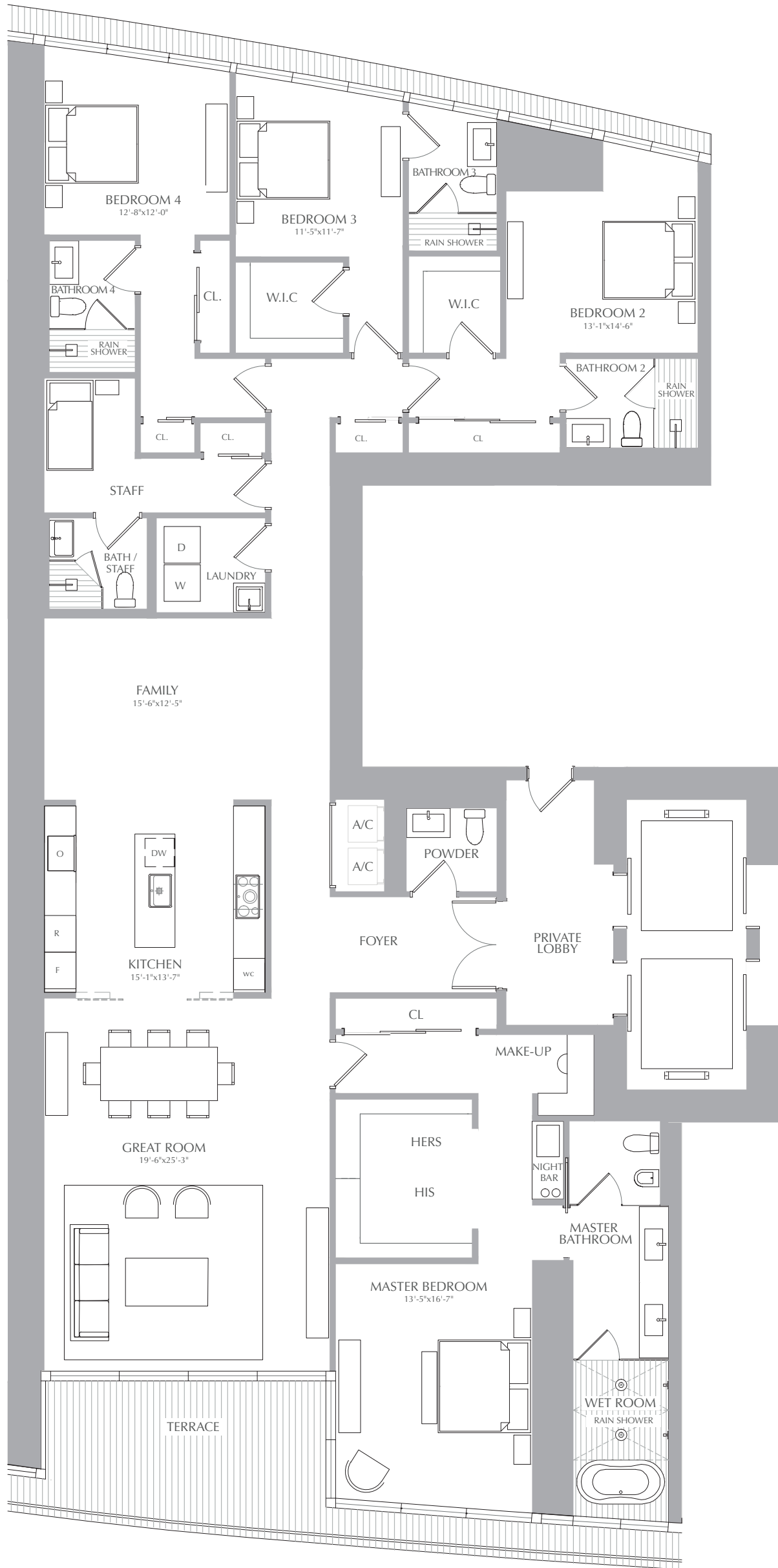
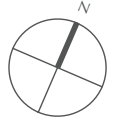

STATED SQUARE FOOTAGES AND DIMENSIONS ARE MEASURED TO THE EXTERIOR BOUNDARIES OF THE EXTERIOR WALLS AND THE CENTERLINE OF INTERIOR DEMISING WALLS AND IN FACT VARY FROM THE SQUARE FOOTAGE AND DIMENSIONS THAT WOULD BE DETERMINED BY USING THE DESCRIPTION AND DEFINITION OF THE "UNIT" SET FORTH IN THE DECLARATION (WHICH GENERALLY ONLY INCLUDES THE INTERIOR AIRSPACE BETWEEN THE PERIMETER WALLS AND EXCLUDES ALL INTERIOR STRUCTURAL COMPONENTS AND OTHER COMMON ELEMENTS). THIS METHOD IS GENERALLY USED IN SALES MATERIALS AND IS PROVIDED TO ALLOW A PROSPECTIVE BUYER TO COMPARE THE UNITS WITH UNITS IN OTHER CONDOMINIUM PROJECTS THAT UTILIZE THE SAME METHOD. FOR YOUR REFERENCE, THE AREA OF THE UNIT, DETERMINED IN ACCORDANCE WITH THESE DEFINED UNIT BOUNDARIES, IS 4,369 SQ. FT. MEASUREMENTS OF ROOMS SET FORTH ON THIS FLOOR PLAN ARE GENERALLY TAKEN AT THE FARTHEST POINTS OF EACH GIVEN ROOM (AS IF THE ROOM WERE A PERFECT RECTANGLE), WITHOUT REGARD FOR ANY CUTOUTS OR VARIATIONS. ACCORDINGLY, THE AREA OF THE ACTUAL ROOM WILL TYPICALLY BE SMALLER THAN THE PRODUCT OBTAINED BY MULTIPLYING THE STATED LENGTH AND WIDTH. ALL DIMENSIONS ARE ESTIMATES WHICH WILL VARY WITH ACTUAL CONSTRUCTION, AND ALL FLOOR PLANS, SPECIFICATIONS AND OTHER DEVELOPMENT PLANS ARE SUBJECT TO CHANGE AND WILL NOT NECESSARILY ACCURATELY REFLECT THE FINAL PLANS AND SPECIFICATIONS FOR THE DEVELOPMENT. ALL DEPICTIONS OF APPLIANCES, COUNTERS, SOFFITS, FLOOR COVERINGS AND OTHER MATTERS OF DETAIL, INCLUDING, WITHOUT LIMITATION, ITEMS OF FINISH AND DECORATION, ARE CONCEPTUAL ONLY AND ARE NOT NECESSARILY INCLUDED IN EACH UNIT.



RESIDENCES

at
300 BISCAYNE BOULEVARD WAY
MIAMI

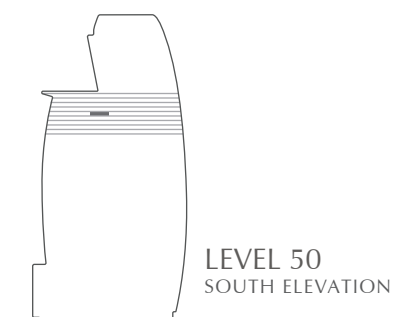
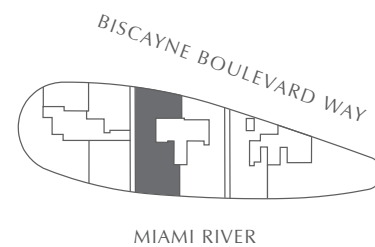
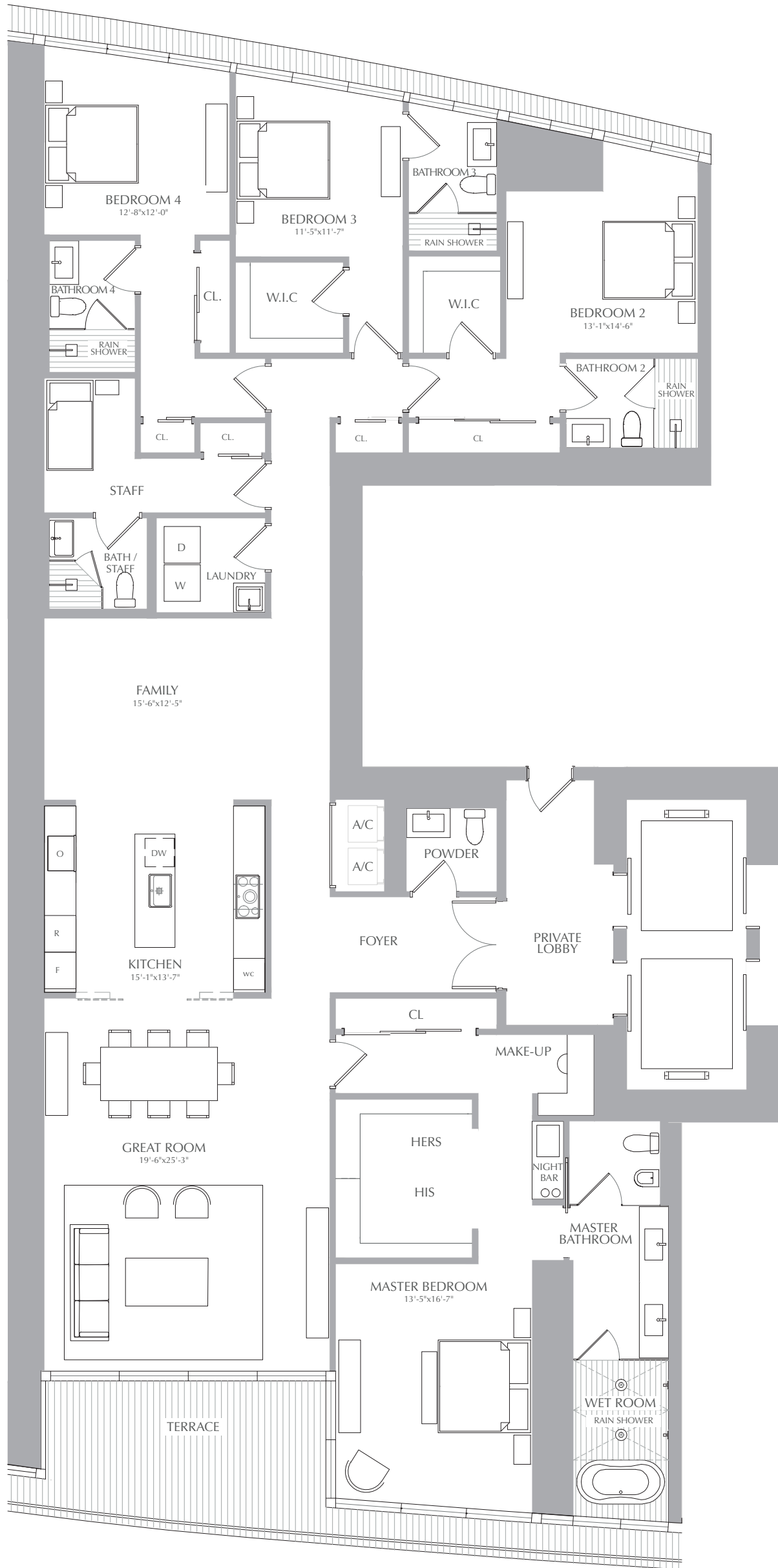
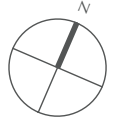

STATED SQUARE FOOTAGES AND DIMENSIONS ARE MEASURED TO THE EXTERIOR BOUNDARIES OF THE EXTERIOR WALLS AND THE CENTERLINE OF INTERIOR DEMISING WALLS AND IN FACT VARY FROM THE SQUARE FOOTAGE AND DIMENSIONS THAT WOULD BE DETERMINED BY USING THE DESCRIPTION AND DEFINITION OF THE "UNIT" SET FORTH IN THE DECLARATION (WHICH GENERALLY ONLY INCLUDES THE INTERIOR AIRSPACE BETWEEN THE PERIMETER WALLS AND EXCLUDES ALL INTERIOR STRUCTURAL COMPONENTS AND OTHER COMMON ELEMENTS). THIS METHOD IS GENERALLY USED IN SALES MATERIALS AND IS PROVIDED TO ALLOW A PROSPECTIVE BUYER TO COMPARE THE UNITS WITH UNITS IN OTHER CONDOMINIUM PROJECTS THAT UTILIZE THE SAME METHOD. FOR YOUR REFERENCE, THE AREA OF THE UNIT, DETERMINED IN ACCORDANCE WITH THESE DEFINED UNIT BOUNDARIES, IS 4,369 SQ. FT. MEASUREMENTS OF ROOMS SET FORTH ON THIS FLOOR PLAN ARE GENERALLY TAKEN AT THE FARTHEST POINTS OF EACH GIVEN ROOM (AS IF THE ROOM WERE A PERFECT RECTANGLE), WITHOUT REGARD FOR ANY CUTOUTS OR VARIATIONS. ACCORDINGLY, THE AREA OF THE ACTUAL ROOM WILL TYPICALLY BE SMALLER THAN THE PRODUCT OBTAINED BY MULTIPLYING THE STATED LENGTH AND WIDTH. ALL DIMENSIONS ARE ESTIMATES WHICH WILL VARY WITH ACTUAL CONSTRUCTION, AND ALL FLOOR PLANS, SPECIFICATIONS AND OTHER DEVELOPMENT PLANS ARE SUBJECT TO CHANGE AND WILL NOT NECESSARILY ACCURATELY REFLECT THE FINAL PLANS AND SPECIFICATIONS FOR THE DEVELOPMENT. ALL DEPICTIONS OF APPLIANCES, COUNTERS, SOFFITS, FLOOR COVERINGS AND OTHER MATTERS OF DETAIL, INCLUDING, WITHOUT LIMITATION, ITEMS OF FINISH AND DECORATION, ARE CONCEPTUAL ONLY AND ARE NOT NECESSARILY INCLUDED IN EACH UNIT.



RESIDENCES

at
300 BISCAYNE BOULEVARD WAY
MIAMI

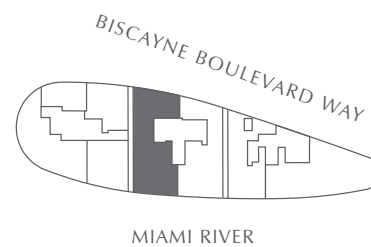
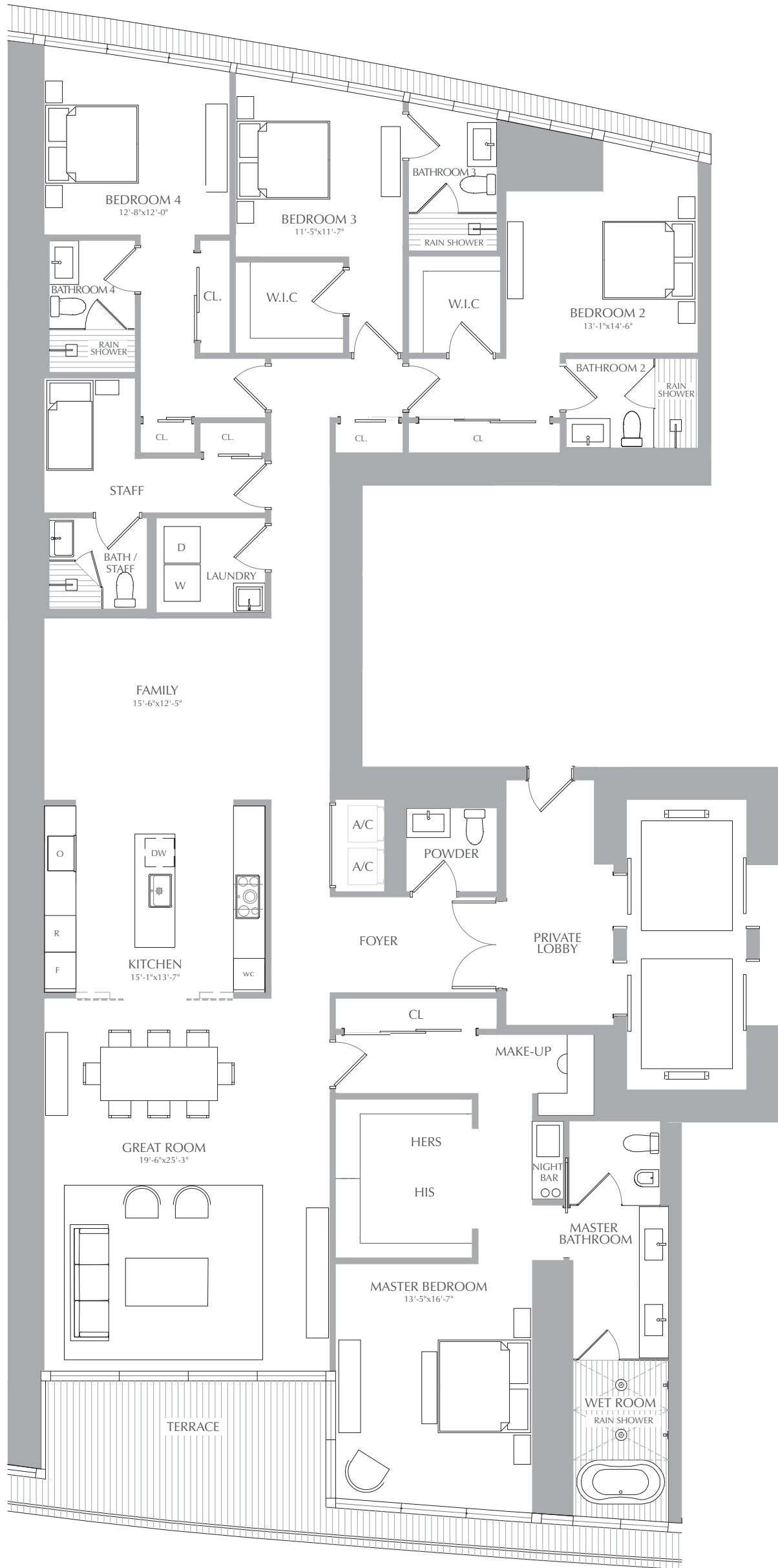
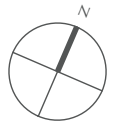

STATED SQUARE FOOTAGES AND DIMENSIONS ARE MEASURED TO THE EXTERIOR BOUNDARIES OF THE EXTERIOR WALLS AND THE CENTERLINE OF INTERIOR DEMISING WALLS AND IN FACT VARY FROM THE SQUARE FOOTAGE AND DIMENSIONS THAT WOULD BE DETERMINED BY USING THE DESCRIPTION AND DEFINITION OF THE "UNIT" SET FORTH IN THE DECLARATION (WHICH GENERALLY ONLY INCLUDES THE INTERIOR AIRSPACE BETWEEN THE PERIMETER WALLS AND EXCLUDES ALL INTERIOR STRUCTURAL COMPONENTS AND OTHER COMMON ELEMENTS). THIS METHOD IS GENERALLY USED IN SALES MATERIALS AND IS PROVIDED TO ALLOW A PROSPECTIVE BUYER TO COMPARE THE UNITS WITH UNITS IN OTHER CONDOMINIUM PROJECTS THAT UTILIZE THE SAME METHOD. FOR YOUR REFERENCE, THE AREA OF THE UNIT, DETERMINED IN ACCORDANCE WITH THESE DEFINED UNIT BOUNDARIES, IS 4,369 SQ. FT. MEASUREMENTS OF ROOMS SET FORTH ON THIS FLOOR PLAN ARE GENERALLY TAKEN AT THE FARTHEST POINTS OF EACH GIVEN ROOM (AS IF THE ROOM WERE A PERFECT RECTANGLE), WITHOUT REGARD FOR ANY CUTOUTS OR VARIATIONS. ACCORDINGLY, THE AREA OF THE ACTUAL ROOM WILL TYPICALLY BE SMALLER THAN THE PRODUCT OBTAINED BY MULTIPLYING THE STATED LENGTH AND WIDTH. ALL DIMENSIONS ARE ESTIMATES WHICH WILL VARY WITH ACTUAL CONSTRUCTION, AND ALL FLOOR PLANS, SPECIFICATIONS AND OTHER DEVELOPMENT PLANS ARE SUBJECT TO CHANGE AND WILL NOT NECESSARILY ACCURATELY REFLECT THE FINAL PLANS AND SPECIFICATIONS FOR THE DEVELOPMENT. ALL DEPICTIONS OF APPLIANCES, COUNTERS, SOFFITS, FLOOR COVERINGS AND OTHER MATTERS OF DETAIL, INCLUDING, WITHOUT LIMITATION, ITEMS OF FINISH AND DECORATION, ARE CONCEPTUAL ONLY AND ARE NOT NECESSARILY INCLUDED IN EACH UNIT.